

ESB100NH40S

Ultra-Fast Soft Recovery Diode Module

Features

- Repetitive Reverse Voltage : $V_{RRM} = 400V$
- Low Forward Voltage Drop : $V_F(\text{typ.}) = 1.05V$
- Average Forward Current : $I_F(\text{AV.}) = 100A @ T_c = 100^\circ C$
- Ultra-Fast Reverse Recovery Time : $t_{rr}(\text{typ.}) = 90 \text{ ns}$
- Extensive Characterization of Recovery Parameters
- Reduced EMI and RFI
- Non Isolation Type Package

Applications

- Welding Machine
- Induction Heating
- UPS

Equivalent Circuit and Package

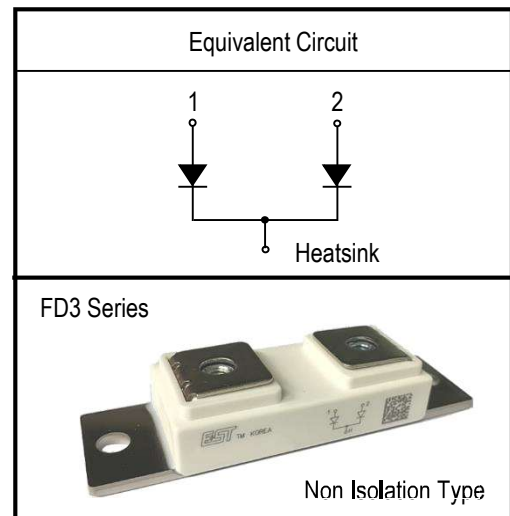

Please see the package out line information

Absolute Maximum Ratings @ $T_c=25^\circ C$ (Per Leg)

Symbol	Parameter	Conditions	Ratings	Unit	
V_{RRM}	Repetitive Peak Reverse Voltage		400	V	
$V_{R(DC)}$	Reverse DC Voltage		320	V	
$I_{F(AV)}$	Average Forward Current	Resistive Load	$T_c = 25^\circ C$	200	A
			$T_c = 100^\circ C$	100	A
$I_{FSM}^{(1)}$	Surge(non-repetitive) Forward Current	One Half Cycle at 60Hz, Peak Value	1400	A	
I_t^2	I_t^2 for Fusing	Value for One Cycle Current, $t_w = 8.3\text{ms}$, $T_j = 25^\circ C$ Start	8.13×10^3	A^2s	
$T_j^{(2)}$	Junction Temperature	-	-40 ~ 125	$^\circ C$	
T_{stg}	Storage Temperature	-	-40 ~ 125	$^\circ C$	
P_d	Maximum Power Dissipation		1000	W	
-	Mounting screw torque	M6	4.0	N.m	
-	Mounting terminals screw torque	M6	3.0	N.m	

(Note *1) Repetitive rating : Pulse width limited by max junction temperature

(Note *2) The maximum junction temperature of chip is $175^\circ C$

■ Electrical Characteristics of FRD @ $T_c=25^\circ\text{C}$ (unless otherwise specified)

Symbol	Parameter	Conditions	Min.	Typ.	Max.	Unit	
V_R	Cathode Anode Breakdown Voltage	$I_R = 100\mu\text{A}$	400	-	-	V	
V_{FM}	Maximum Forward Voltage	$I_{FM} = 100\text{A}$	$T_j = 25^\circ\text{C}$	-	1.05	1.4	V
			$T_j = 125^\circ\text{C}$	-	0.95	-	
I_{RRM}	Repetitive Peak Reverse Current	$T_C = 100^\circ\text{C}$, V_{RRM} applied	-	-	1.0	mA	
t_{rr}	Reverse Recovery Time	$I_{FM} = 100\text{A}$, $V_R = 200\text{V}$ $di/dt = -500\text{A}/\mu\text{s}$	$T_j = 25^\circ\text{C}$	-	90	140	ns
			$T_j = 125^\circ\text{C}$	-	140	-	

■ Thermal Characteristics and Weight

Symbol	Parameter	Conditions	Min.	Typ.	Max.	Unit
$R_{\theta JC}$	Junction-to-Case	per FRD	-	-	0.15	$^\circ\text{C}/\text{W}$
Weight	Weight of Module		-	-	95	g

■ Performance Curves

Fig. 1 Typical Forward Voltage Drop vs. Instantaneous Current

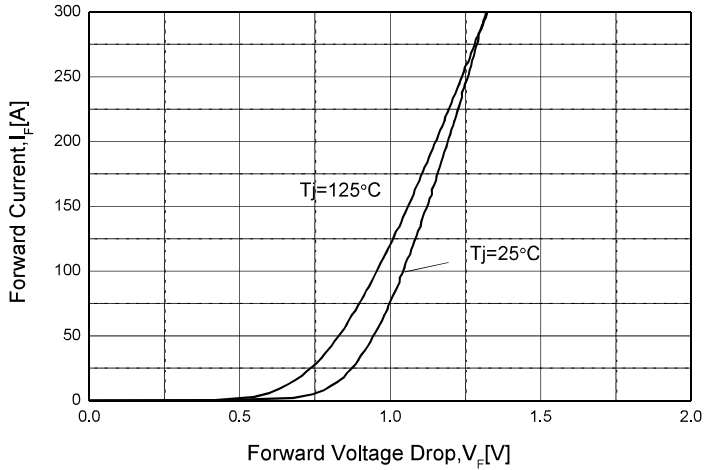

Fig. 2 Typical Reverse Recovery Time vs. $-di/dt$

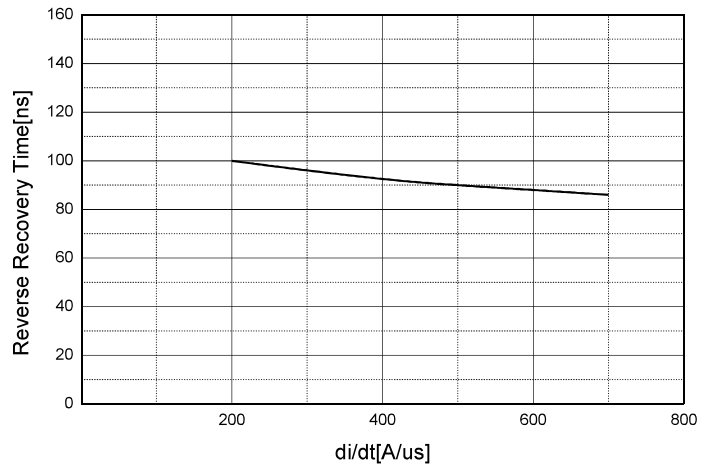

Fig. 3 Transient Thermal Impedance (Z_{thjc}) Characteristics

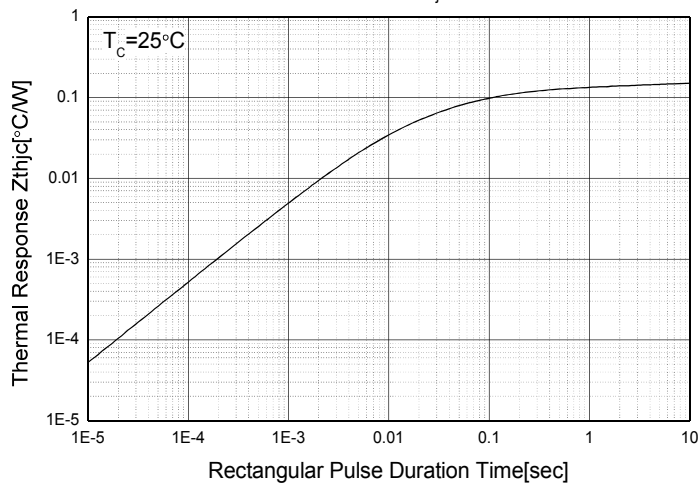
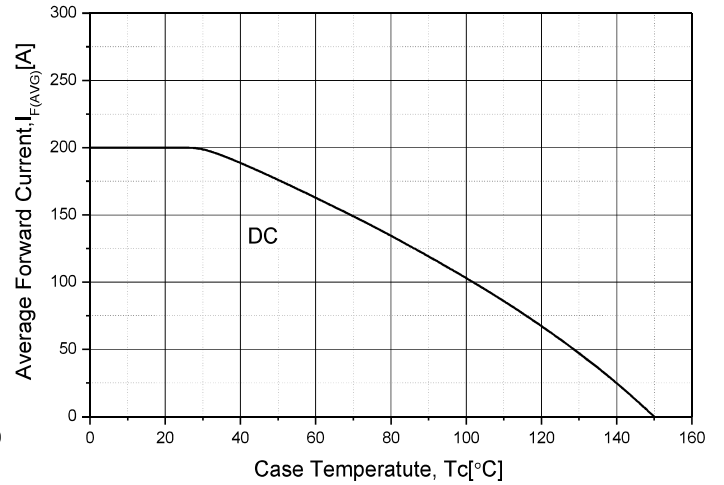

Fig. 4 Forward Current Derating Curve



■ Package Out Line Information

FD3 Package

Dimensions in mm

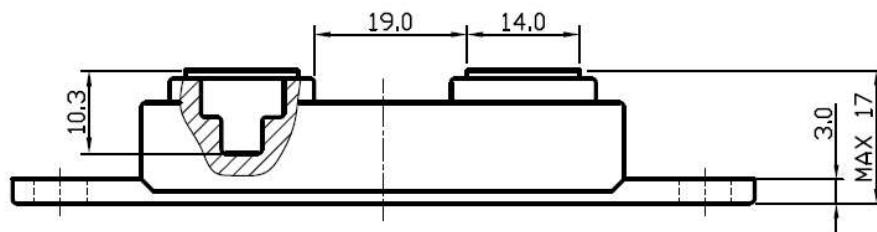
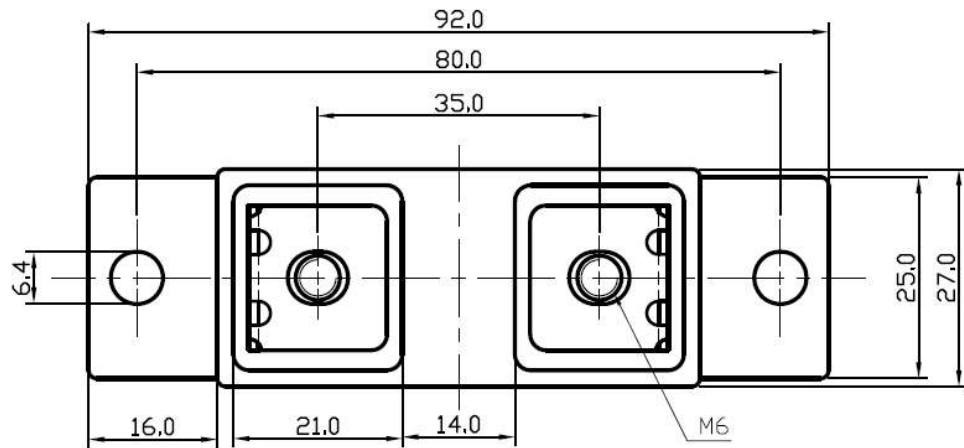

■ Internal Circuit

